

FairPick Quick Assembly

Step 1 Attach the vertical support beams to the base and secure both sides.

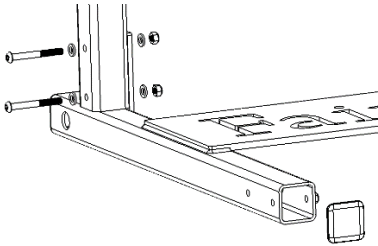

Fasteners:

- M6x55 bolts
- M6 washers
- M6 nuts

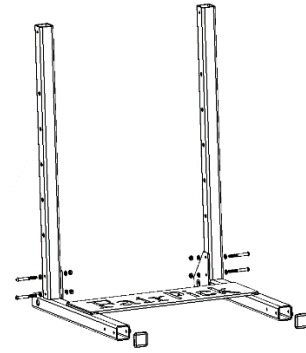

Step 2 Attach the scale to the scale supports and secure all four corners.

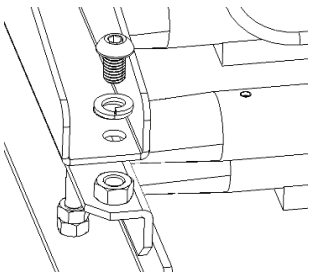

Fasteners:

- M10x16 bolts
- M10 washers

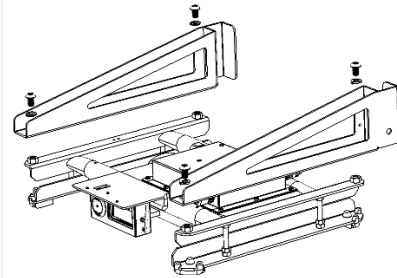

Step 3 Slide the scale assembly down the frame and secure both sides.

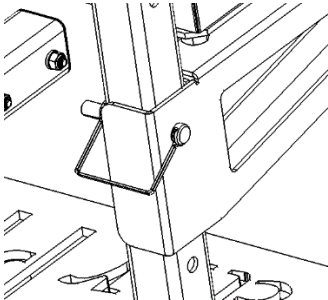

Fasteners:

- Clevis pins

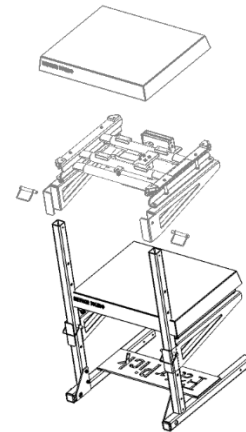

Step 4 Insert the electronics box and handle onto the base frame. Secure both sides.

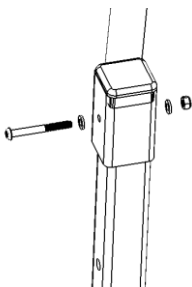

Fasteners:

- M6x55 bolts
- M6 washers
- M6 nuts

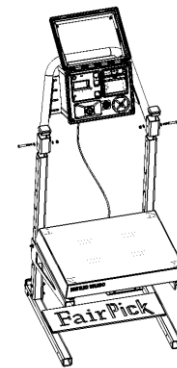

Step 5 Plug the electronics box to the scale and secure the cable.

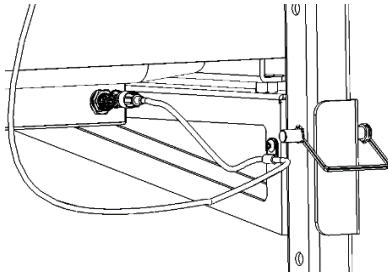

Fasteners:

- P-clamp
- M5x8 bolt

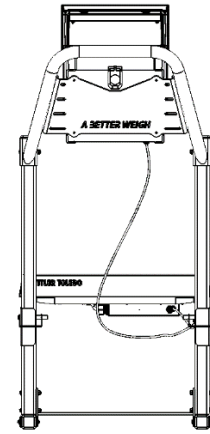

Step 6 Insert the axle rod through the bottom two holes at the back of the machine.

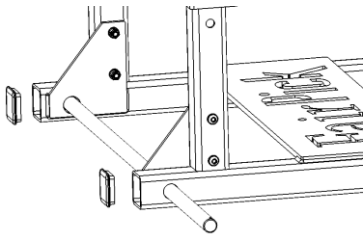

Step 7 Place a washer on the rod, then the wheel, then another washer, and finally a spring clip.

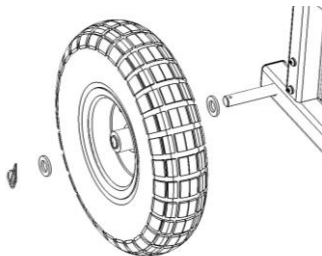

Fasteners:

- Spring Clips
- Axle Washers



Step 8 Attach the Leveling Feet to the base frame. Press the spring bolt to slide the leveling foot rail into place.

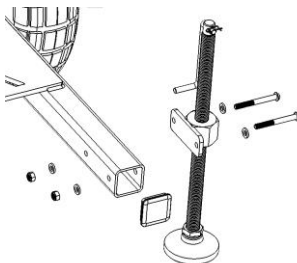

Fasteners:

- M6x55 bolts
- M6 washers
- M6 nuts

